



Subwoofer Owner's Manual:

SLIMsub™ 66

© 2009 PINNACLE LOUDSPEAKERS

We congratulate and thank you for choosing a PINNACLE® SLIMsub 66™ subwoofer. This uniquely versatile subwoofer can be placed on a shelf or floor, flush wall mounted horizontally or vertically, pivot bracket mounted in any orientation, or placed under or behind your sofa, table or chair! Designed to work with our PIN AMP 800 amplifier, you can drive one, or multiple, SLIMsub 66 subs to impressive depths & volume levels. For a powerful "wall of bass" we recommend using two SLIMsub 66 subs in the front, or for a unique & enveloping surround subwoofer system, four SLIM SUB 66s can also be employed, two in the front, two in the rear.

PLACEMENT:

Recommended Subwoofer Placement:

- a) Within a few inches of the room corner closest to your left or right front speaker (maximum low bass output);
- b) Against the wall between your left and right front speakers (strong low bass output with optimal blending to front speakers);
- c) Near any other room corner or wall.

Other locations will provide varying degrees of low bass impact and blending with your front speakers. We recommend listening to your system, with the subwoofer in different room positions, to obtain a location with an optimum response.

- When placing the SLIMsub 66 on a shelf or floor, please attach the 4 rubber pads to the bottom corners of the cabinet.
- When placing the SLIMsub 66 on it's back, please attach the 4 rubber pads to the corners on the rear of the cabinet.
- For pivot wall mounting, use (2) pivot brackets with a weight capacity of at least 12 pounds each. Simply unscrew the two decorative plugs on the rear of the cabinet to access the threaded inserts.

FLUSH WALL MOUNTING INSTRUCTIONS:

Please note: The hanging methodology employed with this product is intended for mounting on walls of standard construction, which includes most residential and business office environments. Such environments are constructed with wooden studs behind the walls that will securely accept the enclosed screw. If you do not notice resistance behind the wall when drilling the pilot hole you probably do not have a stud in that location and will then need to use the enclosed wall anchor.

TOOLS REQUIRED:

#2 Philips head screwdriver bit or hand screwdriver.

Drill - electric or cordless, with 1/8" & 3/8" bits.

WALL MOUNTING INSTRUCTIONS:

- 1) Place the subwoofer on the wall, oriented either vertically or horizontally, at the desired mounting location.
For Vertical Mounting: Make a small mark on the wall at the top center of the cabinet.
For Horizontal Mounting: Make a small mark on the wall at the bottom center of the cabinet.
Remove the subwoofer from the wall.
- 2) Place the mounting bracket on the wall, level, with the outer flanges of the mounting bracket touching the wall.
For Vertical Mounting: Align the mounting bracket so that the mark on the wall is 3/16" above the top center of the mounting bracket.
For Horizontal Mounting: Align the mounting bracket so that the mark on the wall is 3/16" below the bottom center of the mounting bracket.
- 3) Mark the locations for the mounting bracket's four corner mounting screws on the wall. Remove the mounting bracket from the wall.
- 4) Using a drill with a 1/8" bit if mounting into a stud, or a 3/8" bit (and then inserting the included wall anchors) where there is no stud, drill a 2 1/4" deep pilot hole at each of the mounting screw hole marks on the wall. Pre-tapping the wall with a nail or punch will ensure a better grip for the drill bit as it enters the wall.
- 5) Place the mounting bracket back on the wall lining up the mounting screw holes of the mounting bracket with the holes on the wall. Screw the mounting screws fully into the wall anchors or stud. Be sure the screws are inserted straight (perpendicular with wall and parallel with floor) and are securely mounted. The mounting bracket should now be securely attached to the wall.

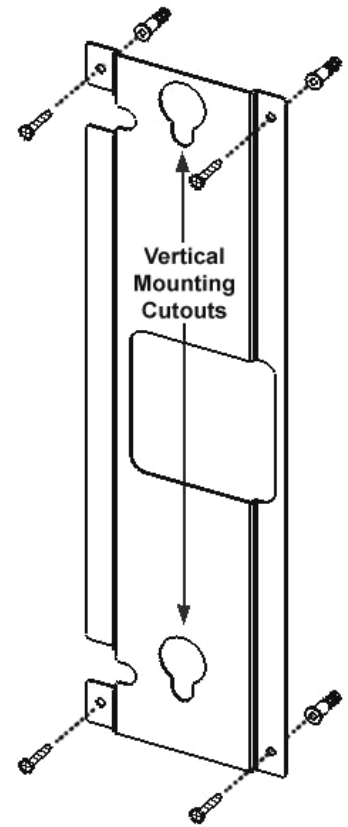
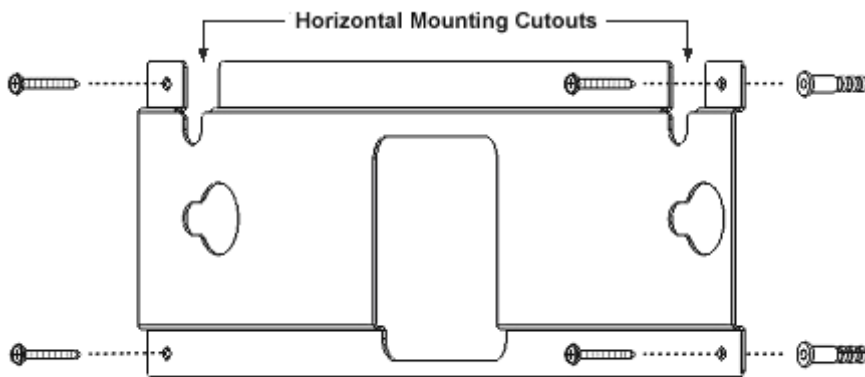

- 6) Unscrew the two decorative plugs on the rear of the subwoofer to access the threaded inserts. Screw both shoulder washers securely to the cabinet.

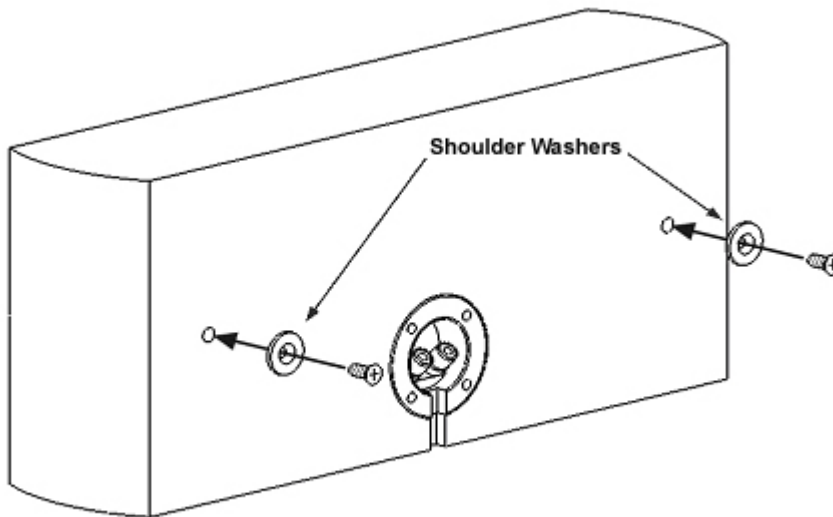

- 7) Attach your wires to the subwoofer, being sure to observe proper polarity (PIN AMP 800 subwoofer output positive (+) to the red terminal, PIN AMP 800 subwoofer output negative (-) to the black terminal).
- 8) Position the subwoofer over the mounting bracket and guide the two shoulder washers into the appropriate cutouts in the mounting bracket. Slowly lower the subwoofer approximately 3/4" until the cabinet comes to a rest. The subwoofer should now be secure.

CONNECTIONS:

Please note that usage of the SLIMsub 66 with any amplifier other than our custom designed PIN AMP 800 is not recommended and will result in seriously degraded performance or product damage. Complete all wire connections in your Home Theater / sound system before powering up your receiver or subwoofer(s). Be sure to observe proper polarity for all subwoofer wire connections (+ to +, - to -). To obtain the best performance, use only speaker wire of 12, 14, or 16 gauge (available from your dealer). Lightweight speaker wire (20, 22 gauge, etc.) will result in degraded performance; 16 gauge wire may be used for short runs of about 8 feet or less. When flush wall mounting, or placing the unit on it's back, be sure to use the wire channel on the back of the cabinet.

- For One Subwoofer: Wire your Subwoofer to the top Subwoofer Output binding posts on the PIN AMP 800; be sure to observe proper polarity (+ to +, - to -).
- For Two Subwoofers: Wire one Subwoofer to the top Subwoofer Output binding posts on the PIN AMP 800, the other to the bottom set of Subwoofer Output binding posts; be sure to observe proper polarity (+ to +, - to -).
- For Four Subwoofers: Wire four Subwoofers to the PIN AMP 800 in a series / parallel fashion as depicted below (top Subwoofer Output+ to Sub 1+, Sub 1- to Sub 2+, Sub 2- to top Subwoofer Output-, bottom Subwoofer Output+ to Sub 3+, Sub 3- to Sub 4+, Sub 4- to bottom Subwoofer Output-).

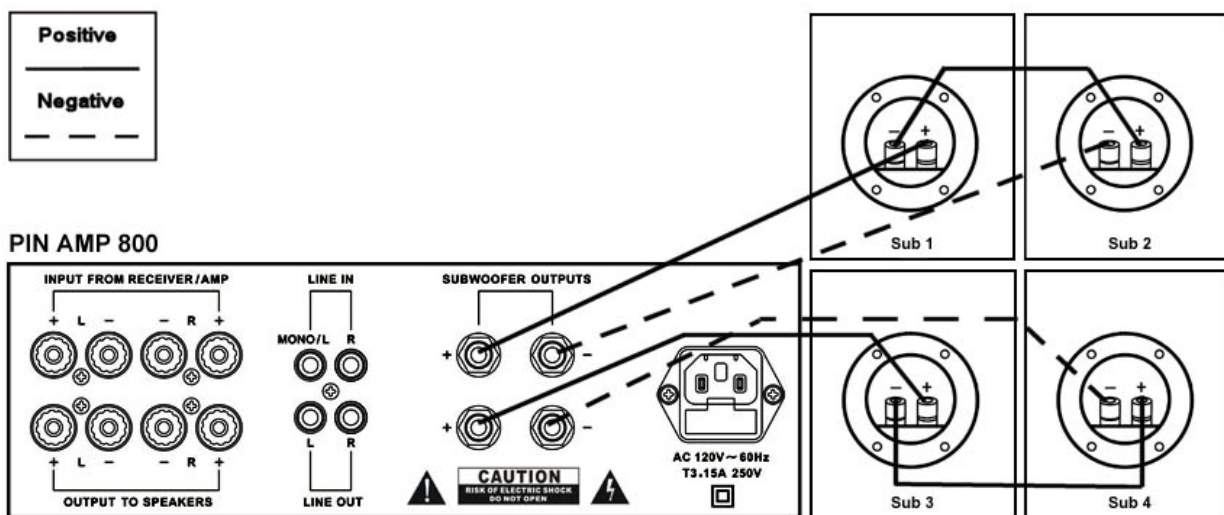

- **Please refer to your PIN AMP 800 owner's manual for proper amplifier setup, adjustments and troubleshooting.**

LIMITED WARRANTY:

What Is Covered

Your Pinnacle[®] subwoofer features a limited warranty as follows. The subwoofer driver(s) and all assembly and construction aspects are covered by this warranty for a period of seven (7) years from the date of original purchase. The warranty covers all necessary parts and labor to return the subwoofer to proper working order. Cabinet surfaces, grille assembly, and other exterior parts subject to normal wear and tear are not covered except where an inherent structural defect becomes evident.

Parts replacement and labor will be performed at the discretion of Pinnacle Loudspeakers and will be provided free of charge unless (in the opinion of our service department, service representatives, or engineering department) the system has failed due to abuse or negligent operation.

What Is Not Covered

This warranty will be void and no free services performed if we or any party acting as our agent determines that the system has had any of its elements (amplifier, woofer, etc.) removed or tampered with in any way whatsoever. Furthermore, if your subwoofer is not found to be defective a service charge will be levied. In either case the minimum charge will be \$30.00. An additional charge will be applicable for same day service where possible and this charge will always be in effect even if the actual parts and labor are covered by this warranty. Pinnacle Loudspeakers reserves the right to make the final determination of whether or not the system has been damaged by abuse or negligent operation.

To Obtain Service

To obtain service under this warranty, either contact your Pinnacle[®] dealer or us directly at (516) 576-9052 or service@pinnaclespeakers.com. If you ship your subwoofer you are responsible for packing and shipping insurance. The freight must be prepaid. We will, however, pay return freight charges on any returned subwoofer that qualifies for in-warranty service. Sorry, we cannot accept any collect freight charges. You must include a note, attached to the unit, with your name, phone number or email address, and return shipping address (no Post Office boxes), indicating the nature of the problem you are experiencing. For warranty service you must also include a copy of your dated sales receipt. **YOU MUST FIRST CONTACT US FOR THE CUSTOMER SERVICE SHIPPING ADDRESS IN YOUR AREA IF YOUR DEALER IS NOT EQUIPPED FOR THIS SERVICE.** Please be sure to pack any items you ship us carefully since we cannot be held responsible for damages incurred during shipping.

This warranty may be transferred to a subsequent owner.

SAVE YOUR ORIGINAL SHIPPING CARTON AND PACKING MATERIALS, AS WELL AS THIS WARRANTY AND YOUR SALES RECEIPT. YOU WILL NEED THEM TO OBTAIN SERVICE UNDER THE PROVISIONS OF THIS LIMITED WARRANTY.



1 Fairchild Court Suite 140
Plainview, NY 11803

Tel. (516) 576 9052, Fax. (516) 576 0826
pinnacle@pinnaclespeakers.com
<http://www.pinnaclespeakers.com>

PR MAN QT REV0109